

# MODULAR CIRCUIT MONITORING SYSTEM



## Contact

**Anord Mardix (USA) Inc.**  
2704 Seven Hills Boulevard,  
Henrico, VA 23231

Email: [us.sales@anordmardix.com](mailto:us.sales@anordmardix.com)  
Call: +1 800 228 4689

[www.linkedin.com/company/anordmardix](https://www.linkedin.com/company/anordmardix)

[www.twitter.com/anordmardix](https://www.twitter.com/anordmardix)

## About Anord Mardix

Anord Mardix is a leading provider of power distribution and protection equipment to the global market. We are a vendor of choice to many of the world's leading data center and cloud computing industries. We produce the most comprehensive product range in the market - from power, control, and monitoring solutions to our unique service capability. Our ability to customize and produce on a large scale delivers the most reliable end-to-end power systems to all our customers, from independent providers to hyper-scale leaders.

[www.anordmardix.com](http://www.anordmardix.com)

- RAPID INSTALLATION
- EASILY ACCESSED DATA
- EASY CONNECTIVITY
- INTELLIGENT FEATURES
- HIGH ACCURACY



**ANORD MARDIX**  
A Flex Company

[www.anordmardix.com](http://www.anordmardix.com)



## Energy Monitoring Revolutionized

The Anord Mardix Modular Circuit Monitoring System is redefining circuit monitoring with next generation technology that simplifies installation and connectivity while providing instant access to data in a user-friendly format. The versatile Core Module™ system is a single monitoring solution with peripherals optimized for branch circuit and multi-circuit monitoring applications designed to reduce the cost and complexity associated with legacy systems.

### Features

#### Rapid Installation

- Optimized for new and retrofit installations with no disruption to critical loads
- Monitors up to 96 circuits
- Options for solid core, split core CTs, Rogowski coils<sup>1</sup>, and analog, discrete and pulse inputs

#### Easily Access Data

- On-board web server provides immediate access to real-time and logged data
- Integrated data logging supports up to 64 GB storage; remotely accessible or manually exportable
- Available cloud monitoring service
- Customizable alarming features

#### Easy Connectivity

- Select from multiple connectivity options including Modbus TCP/IP, RTU, BACnet, WiFi and cellular
- Open protocols allows connection with any third party monitoring system

#### Intelligent Features

- Presence of voltage detection accurately indicates breaker status even under no load conditions
- Predictive Circuit Health Algorithm (patent pending) detects changes in circuit performance to predict potential failures
- True-Circuit Display mapping function presents data according to actual circuit configurations
- Detailed power and energy monitoring per circuit including Waveform capture and THD

#### High Accuracy

- True 0.5% accuracy suitable for billing applications



Panel A01 ● Circuit 23 - Load Healthy

#### Energy Use Per Circuit (kWh)

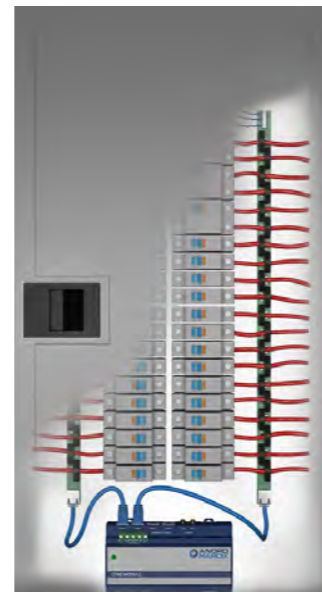
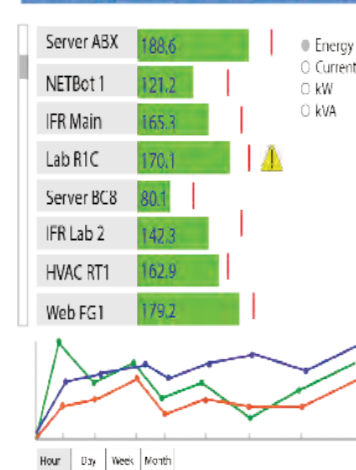

## The Anord Mardix Core Module™ System

The versatile and compact Core Module™ functions as a gateway that can host up to four interface modules monitoring a total of 96 circuits. Interface modules connect via Ethernet cables and are available for new and retrofit branch circuit and multi-circuit applications.

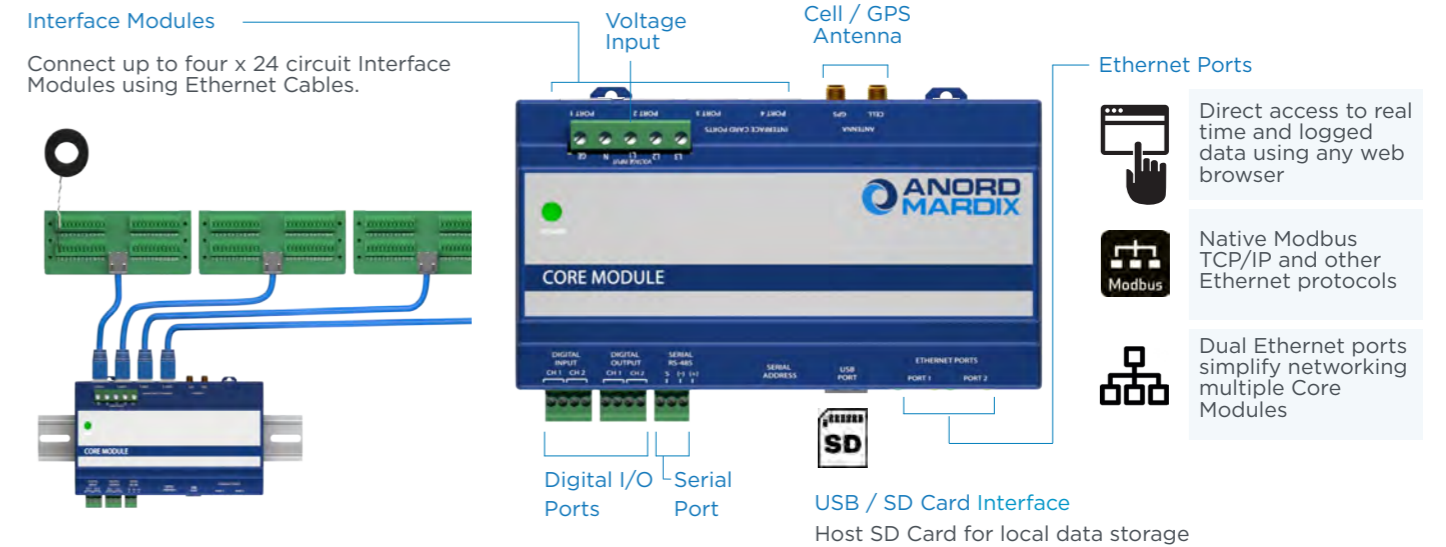

### Interface Modules

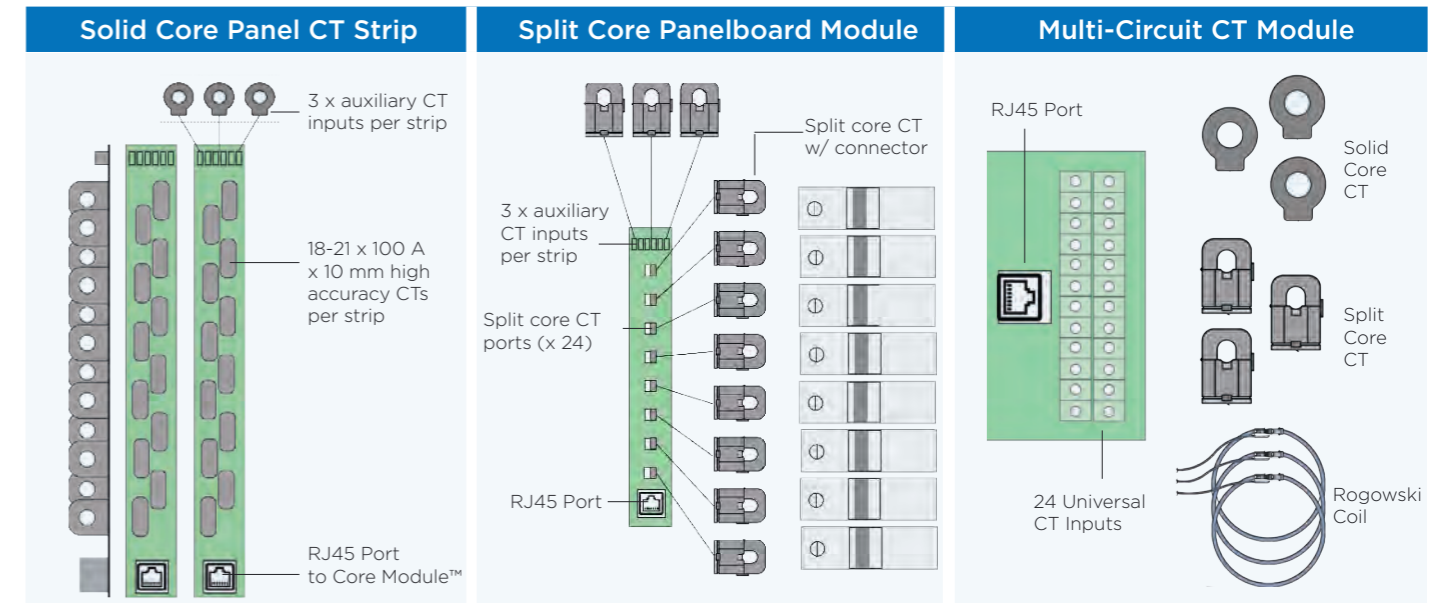

- Used for new installations on panelboard branch circuit monitoring
- Up to 21 circuits per strip + 3 auxiliary CT inputs (96 total)<sup>2</sup>
- 0.75" and 18mm C-C versions
- 10mm CT window w/ 100 A range
- Optional presence of voltage sensing for breaker status per circuit
- Used for retrofit installations on panelboard branch circuit monitoring
- Floating CT interface strip with quick connect 10mm split core CTs sits on top of existing conductors
- 24 circuits per module (96 Total)
- Optional presence of voltage sensing for breaker status per circuit
- 24 CTs / circuits per module (96 Total)
- Supports 0.33 V solid core and split core CTs as well as available native Rogowski coil version available
- Optional presence of v or breaker status per circuit

<sup>1</sup>Consult Interface Module data sheet for specifications and additional modules  
<sup>2</sup>Main input readings can be summed or measured directly using direct CT inputs

## Connectivity Solutions

Anord Mardix makes it easier than ever to connect and access data with a range of connectivity solutions including low cost CAT1 cellular links.

### Connectivity Options

- Modbus TCP/IP and RTU
- HTML
- Wi-Fi
- BACnet
- Embedded Cellular



### Data Acquisition Options

- Web Server**  
On board web server provides access to real time and logged data.
- Data Stream**  
Open protocols feed data to any third party monitoring system
- Cloud**  
View and manage data using the optional plug and play cloud application
- Manual Export**  
Logged data can be manually exported from the core Module™

### Data Presentation

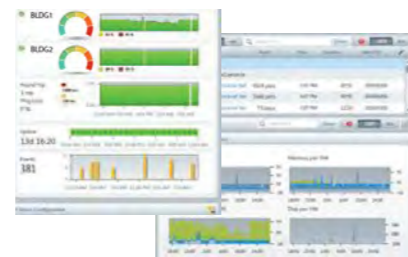

The available cloud monitoring service provides all the functionality of advanced monitoring systems at a fraction of the cost and with no programming.

- Report Generation
- Predictive Analysis
- Trending
- Alarming

## Smart Technology That Makes a Big Difference



**Presence of Voltage Detection** detects circuit breaker status even under no load conditions using a proprietary voltage field detection system identifying failed circuits that may go unnoticed on conventional monitoring systems



**Predictive Circuit Health Analysis** uses proprietary algorithms to analyze circuit signatures over time and detect changes indicative of common failure modes in power supplies and other critical loads



**Waveform Capture:** High resolution power quality data from all circuits is stored for any power quality deviation providing invaluable data for evaluating power disturbances



**True Circuit Display** allows data to be expressed according to the actual panelboard configuration by indicating pole position, circuit type, friendly names and more to each circuit

## Applications



**Colocation Data Centers**  
Colocation data centers often must monitor the health and energy usage of each branch circuit



**Lighting / HVAC Energy Optimization**  
Sub-metering is required to provide the needed resolution to initiate and verify most energy efficiency upgrades

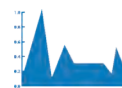

**Demand Management**  
Sub-metering identifies energy use by specific loads allowing them to be managed to avoid peak demand charges



**Tenant Sub-Metering**  
Commercial facilities are increasingly using sub-metering to allocate costs



**Switchgear / Power Distribution**  
Economically identify energy and power use per breaker



**Circuit / Load Health**  
Facilities use sub-metering to verify performance of critical loads



**Energy Use Allocation**  
Larger buildings and campuses require a means of allocating energy usage for costing purposes



**High-End Residential**  
High end residential automation systems can utilize branch circuit sub-metering to enhance reliability and efficiency

## Installation Overview

Anord Mardix reduces the cost of monitoring by simplifying installation and providing instant access to real time and logged data without programming requirements.

1. Mount the compact Core Module onto DIN rail; fits inside most existing enclosures.
2. Mount CT interface cards in most convenient location to minimize CT cable length and connect to monitor using standard network cables.
3. Connect to network and acquire real time and logged data from the monitor or utilize optional embedded cellular modem for affordable wireless connectivity at a cost lower than most network connections.

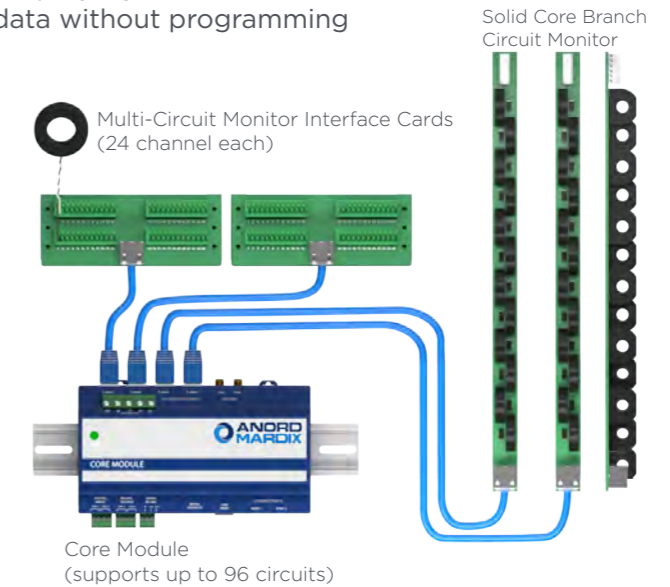

## Product Selection Guide

### Core Module Monitor Feature Set

Feature	Standard	Enhanced
Local Network Access	•	•
Integrated Web Server	•	•
Field Upgradeable Feature Set	•	•
SD Card and Network Configuration	•	•
Modbus TCP/IP output	•	•
Modbus Serial Output	•	•
Integrated Gateway		•
Presence of Voltage Detection		•
BACnet Protocol		•
Integrated Cellular Modem Support		•
Waveform Capture		•
Predictive Health Algorithm		•
True Circuit Display		•
WiFi Output		•
GPS Time Base		•
Local Data Logging		•
SD Card Data Storage		•
Network Data File Export		•
Alarming		•
Pulse Input		•
Native Rogowski Coil Input		•
Thermal Monitoring per Circuit		•

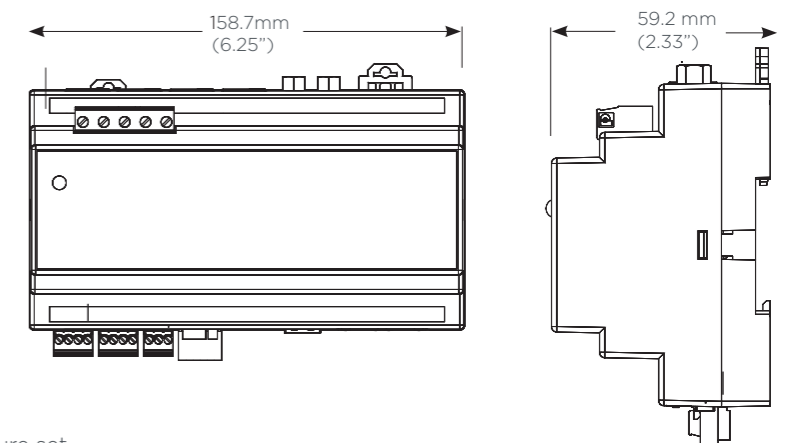

Monitors are available with a Standard and Enhanced feature set.



## Product Selection Guide

See product selection guide online for complete product offering and detailed ordering instructions.

### Core Module™ Monitoring Systems

CM01	Standard Core Module™ monitoring system; expandable up to 96 channels
CM02	Enhanced Core Module™ monitoring with enhanced firmware; expandable up to 96 channels

**Solid Core CT Strip Monitoring System for Installations on New Panelboards** - All systems include 10mm x 100 A solid core CTs and + 3 auxiliary CT terminals per strip for main input CTs

### 0.75" c-c CT strips (21 CTs + 3 auxiliary CT inputs per strip) and Core Module Monitor

iBCM0A42A1	42 pole system with 2 x 21 x 100 A solid core CT strips with 0.75" C-C spacing
iBCM0B42A1	42 pole system with 2 x 21 x 100 A solid core CT strips with 0.75" C-C spacing; includes presence of voltage detection
iBCM0A84A1	84 pole (2 panel) system with 4 x 21 x 100 A solid core CT strips with 0.75" C-C spacing
iBCM0B84A1	84 pole (2 panel) system with 4 x 21 x 100 A solid core CT strips with 0.75" C-C spacing; includes presence of voltage detection

### 18mm c-c CT Strips (18 CTs + 3 auxiliary CT inputs per strip) and Core Module™ Monitor

iBCM2A42A1	36 pole system with 2 x 18 x 100 A solid core CT strips with 0.75" C-C spacing
iBCM2B42A1	36 pole system with 2 x 18 x 100 A solid core CT strips with 0.75" C-C spacing; includes presence of voltage detection
iBCM2A84A1	72 pole system with 4 x 18 x 100 A solid core CT strips with 0.75" C-C spacing
iBCM2B84A1	72 pole system with 4 x 18 x 100 A solid core CT strips with 0.75" C-C spacing; includes presence of voltage detection

### Retrofit Panelboard CT Interface Module (Floating Strip CT Interface Module) and Core Module™ Monitor

Floating Strip CT interface boards reside in raceway and interface with 10mm x 75 A or 100 A split core CTs using plug-in quick connects. Each Core Module™ accommodates up to four interface modules (96 circuits)

iBCM3C24A1	24 channel split core CT monitoring system with 24 split core CTs
iBCM3C48A1	48 channel split core CT monitoring system with 48 split core CTs
iBCM3A72A1	72 channel split core CT monitoring system with 72 split core CTs + 12 aux. CT inputs
iBCM3C42A1	96 channel split core CT monitoring system with 96 split core CTs
iCTS324C	4 channel expansion Panelboard CT Interface Module ; Core Modules™ can accommodate up to 4 x 24 modules



## Product Selection Guide

### Multi-Circuit Monitoring Systems and Core Module™ Monitor

The Multi-Circuit Monitoring system supports up to 4 x 24 CT Interface Cards (96 circuits) and accommodates any 0.33 Volt current transformers or native Rogowski coils. All iMCM systems include the Core Module as well as CT Interface Card specified.

iMCM0A061	6 Channel Multi-Circuit Monitoring System (single CT Interface Card)
iMCM0A121	12 Channel Multi-Circuit Monitoring System (single CT Interface Card)
iMCM0A241	24 Channel Multi-Circuit Monitoring System (single CT Interface Card)
iMCM0A481	48 Channel Multi-Circuit Monitoring System (two CT Interface Cards)
iMCM0A721	72 Channel Multi-Circuit Monitoring System (three CT Interface Cards)
iMCM0A961	96 Channel Multi-Circuit Monitoring System (four CT Interface Cards)
iCTC24A1	24 Channel Expansion Card (each Core Module can accommodate up to four x 24 channel cards)

### Wireless Communication Connectivity Options

iMMCC	Embedded CATM1 cellular modem; must specify region; connectivity plans purchased separately
-------	---

### Current Transformers and Rogowski Coils

See Current Transformer selection guide for details



## Technical Specification

### Inputs

Input power (standard)	90-277 VAC (480 VAC 4W+G) 50/ 60 Hz
Input power (enhanced)	480-600 VAC (3W or 4W+G) 50/ 60 Hz
Voltage connection terminals	22 - 14 AWG
Overload protection	Internally fused
Power consumption	<5W / 0.1 A @ 240 VAC
Channels / circuit capacity	24 x 4 channels (96 circuits total)

### Performance

Accuracy	0.50%
Sampling rate	> 3 kHz

### Communications

Data protocols	Modbus TCP/IP (Ethernet), Modbus RTU (RS-485 2 wire), HTML (web server)
Modbus serial specifications	9600, 19200, 38400 Baud (selectable)
Ethernet ports	2 x RJ-45 10/100 Mbit
USB port	USB 2.0 Type A
Web server	HTML via standard browser
WiFi option	802.11 g/n ; requires WiFi option
Cellular option	CAT 1 / CAT M1; requires subscription

### Environmental

Operating temperature	0 to 60 °C (32 to 140 °F) (<95% RH non-condensing)
Storage temperature	-40 to 70 °C (-40 to 158 °F)
Enclosure versions	NEMA 1/IP20 (indoor use); NEMA 4 / IP67 (outdoor use)

### Approvals

Agency approvals	UL Listed to EN61010-1, Cat. III, pollution degree 2, CE
------------------	--

## Technical Specification

### Monitored Parameters

Monitored Parameter	Per Circuit	Total Load <sup>1</sup>
Current per phase	•	•
Max. current per phase	•	•
Avg. Current per phase	•	•
Current demand per phase	•	•
Max. current demand per phase	•	•
Current phase angle	•	•
Voltage phase angle	•	•
Real power (kW) per phase	•	•
Real power (kW) demand per phase	•	•
Real power (kW) demand max	•	•
Energy (kWh) per phase	•	•
Power factor	•	•
Power factor vector	•	•
Apparent power (kVA)	•	•
Reactive power (kVA)	•	•
THDI	•	•
THDV	•	•
Voltage, L-L and average		•
Voltage, L-N and average		•
Voltage, L-N and per phase		•
Waveform capture	•	•
Circuit Health <sup>3</sup>	•	•
Presence of Voltage <sup>3</sup>	•	•
Ground current <sup>2</sup>	•	•

<sup>1</sup>Total load data can be calculated by summing up branch CT measurements or directly measured using CTs

<sup>2</sup>Required optional ground current CT connected to auxiliary CT input

<sup>3</sup>Optional feature